



LOCAL AREA NETWORKS (LAN)



SERVERS



DATA CENTRES



TELECOM-MUNICATIONS DEVICES



E-BUSINESS (Servers Farms, ISP/ASP/POP)



INDUSTRIAL PROCESSES



INDUSTRIAL PLCS



ELECTRO-MEDICAL DEVICES



EMERGENCY DEVICES (Lights/Alarms)

Master MPS

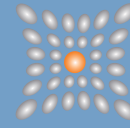

Pure Power Systems
UPS Systems & Power Quality Specialists

10-800 kVA
Three-phase/Three-phase

10-100 kVA
Three-phase/Single-phase



Highlights

- Efficiency Control System (ECS)
- Galvanic isolation
- High overload capacity
- LCD display
- Extensive parallel configurations



Total protection

MASTER MPS series UPS provides maximum protection and power quality for critical loads, including data centres, industrial processes, telecommunications, security and electro-medical systems. The UPS is an On-line double conversion UPS (VFI SS 111 - IEC EN 62040-3) with a transformer isolated inverter.

The MASTER MPS range includes three-phase input and single-phase output versions from 10 to 100kVA, and three-phase input and output versions from 10 to 800kVA. Three phase MPS models from 10 to 200 kVA are available with a 6 or 12-pulse thyristor-based rectifier. From 100 to 500 kVA, the Master HP series has an IGBT-based rectifier, to



Pure Power Systems
UPS Systems & Power Quality Specialists

Tel: +353 (0) 1 6205495 - Fax: +353 (0) 1 6205496 - Email: info@ppsystems.ie - Web: www.ppsystems.ie

provide lower harmonic input current distortion (THDi) and a high input power factor (see Master HP section). From 600 to 800kVA, Master MPS have a 12-pulse rectifier and optional harmonic filters.

Easy source

MASTER MPS technology removes the problems of oversizing upstream power sources, whilst improving load power factors and current harmonics. The MPS range features the latest input-current absorption techniques including progressive rectifier start-up and the option to reduce battery charging currents. These features make the MASTER MPS series one of the most generator and environmentally friendly UPS available.

Power continuity

For years, Riello UPS has developed and supplied solutions for dealing with the different requirements and the problems that inevitably arise in critical applications. Riello UPS offers flexible, high-availability solutions that are able to adapt to different system structures and critical levels. Riello UPS creates UPS systems that can tolerate a number of component or subsystem failures, while continuing to operate normally, to provide service without interruption.

This is achieved by installing carefully designed redundant elements, eliminating common failure points, scheduling maintenance activities and through the control and supervision of the operating parameters of the system and the environment. The TEC service team is ready to provide guidance and advice on projects.

Flexibility

MASTER MPS is suitable for a wide range of applications including IT and the most demanding industrial environments. The UPS is suitable for power capacitive loads such as blade servers, without any reduction in active power, from 0.9 leading to 0.8 lagging. With a broad range of accessories and options, complex configurations and system architectures can be achieved to guarantee maximum power availability and the option to add new UPS without interruption to existing users. Using the Riello UPS Group Synchroniser (UGS) and Parallel Systems Joiner (PSJ), sophisticated inter group

parallel and redundant systems can be achieved to provide the highest possible levels of resilience and availability.

Battery care system: maximum battery care

Normally the batteries are kept charged by the rectifier; when mains power fails, the UPS uses this energy source to power the inverter loads. Therefore, proper battery care is critical to ensuring correct UPS operation in emergency conditions. The Riello UPS Battery Care System consists of a series of features and capabilities to optimise battery management and obtain the best performance and operating life possible.

- Dual level charging regime to optimise recharge currents and reduce charge times
- Temperature compensation and deep discharge protection to reduce overall battery ageing
- Charge blocking system to reduce electrolyte consumption and lengthen the life of VRLA batteries
- Battery tests to diagnose, in advance, any reduction in performance or problems with the batteries.

MASTER MPS is also compatible with different battery technologies: vented open lead acid, VRLA AGM and NiCd.

Ease of Installation

MASTER MPS requires only a very small space for installation (only 0.64 sqm for a 200KVA system); in addition, front access allows servicing of all major components from the front panel, making side access unnecessary. MASTER MPS requires minimal space for access, utilising top-cabinet ventilation and front panel access.

Specific solutions

The UPS can be adapted to meet your requirements. Contact our TEC team to discuss specific solutions and options not listed in this catalogue.

Advanced communication

- Compatible with TeleNetGuard for remote monitoring.
- Advanced communication, multi-platform, for all operating systems and network environments: Supervision and shutdown PowerShield³ software for Windows operating systems 7, 2008, Vista, 2003, XP, Linux, Mac OS X, Sun

Solaris, Linux, Novell and other Unix operating systems.

- UPS is supplied with a cable for direct PC connection (Plug and PLayer)
- RS232 double serial port
- Communications slot for network adapter installation; ESD contact (Emergency Switching Device) for switching off the UPS by remote emergency button.
- Remote LED mimic panel or graphic display.

Maximum reliability and availability

Distributed or centralised parallel configuration of up to 8 units per redundant (N+1) or power parallel system, even using different power ratings.

Hot System Expansion (HSE): allows the addition of a further UPS into an existing system, without the need to switch off the UPS or transfer them to bypass mode.

This guarantees maximum load protection, even during maintenance and system expansion.

Maximum levels of availability, even in the event of an interruption to the parallel bus cable: the system is "FAULT TOLERANT".

It is not affected by connection cable faults and continues powering the load without disruption, signalling an alarm condition.

Efficiency Control System (ECS): a system to optimise the operating efficiency of parallel systems, according to the power required by the load. N +1 redundancy is guaranteed, with every UPS working in parallel at the best load level possible.

OPTIONS

- UPS Group Synchroniser (UGS): allows two or more non-parallel UPS devices to remain synchronised even during mains power failure. The UGS also enables a Riello UPS to be synchronised with another power source that is independent and of a different power rating.

- Parallel Systems Joiner (PSJ): connects two UPS groups in parallel configurations through a power couplign switch. The Slave UPS group is permanently synchronised to the master group. Should one of the UPS in one of the parallel groups fail, the PSJ will automatically connect the remaining UPS to the other group via an external bypass.

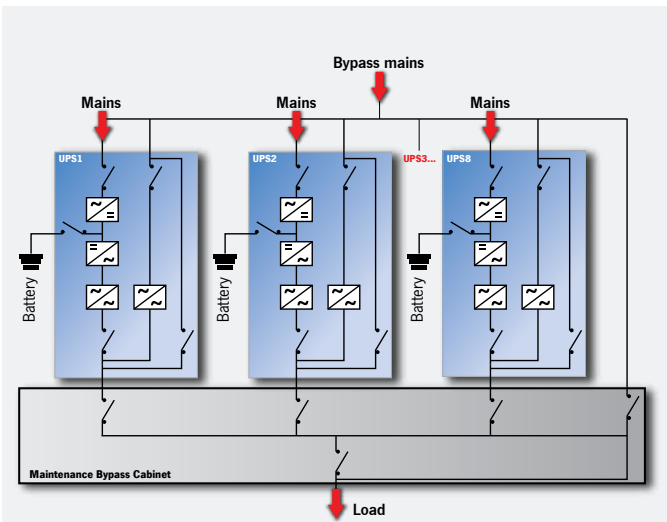

Parallel configuration of up to 8 units with distributed bypass

Parallel architecture to ensure redundancy of the power mains source. **+Flexibility and modularity**

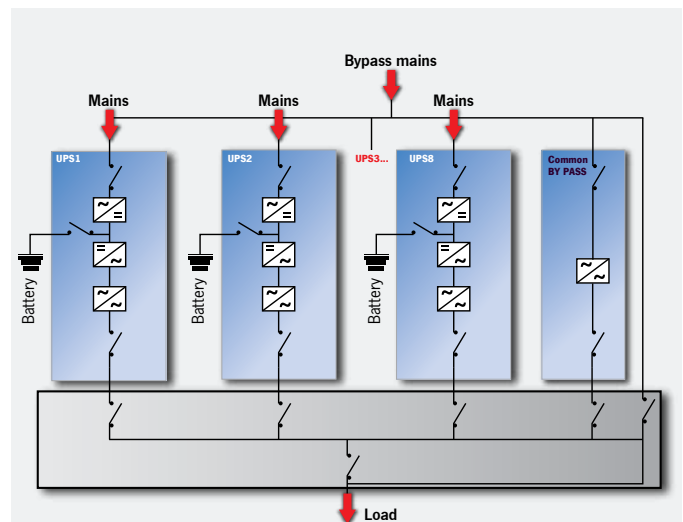

Parallel configuration of up to 8 units with common bypass

Parallel architecture to ensure redundancy of the power source, with autonomous bypass management. **+ Selectivity of downstream faults in bypass mode**

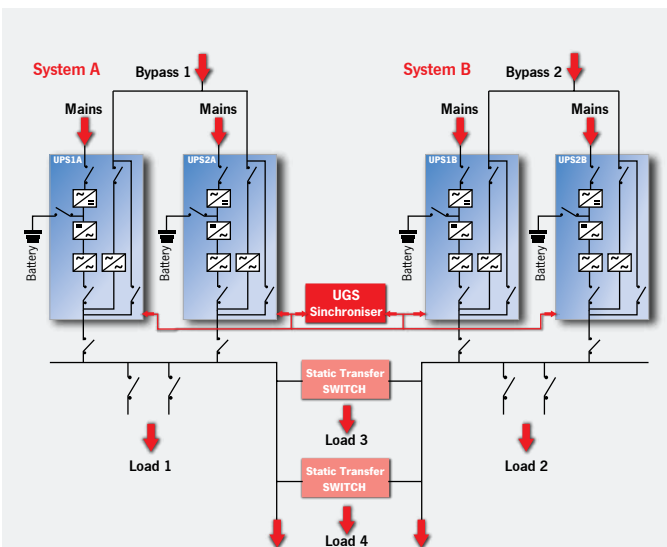

Dynamic dual bus configuration

Solution to ensure redundancy until the distribution of the power supply to the loads **+ Downstream fault discrimination**

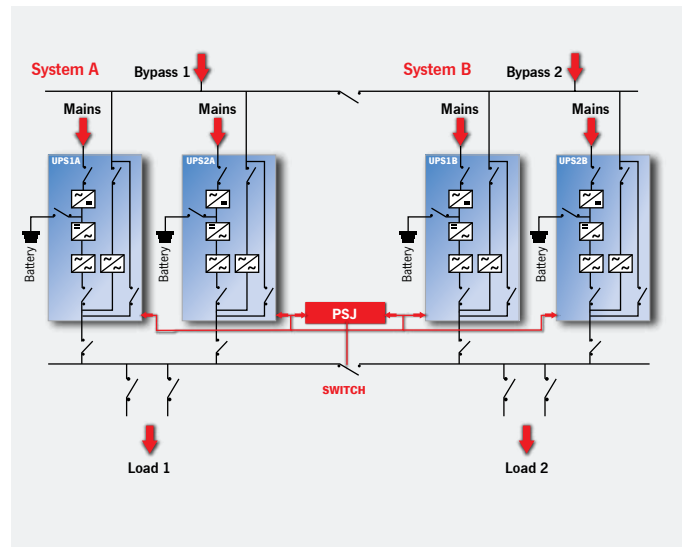

Dual bus system configuration

Solution to ensure redundancy of the power supply even during maintenance **+ High availability and redundancy**



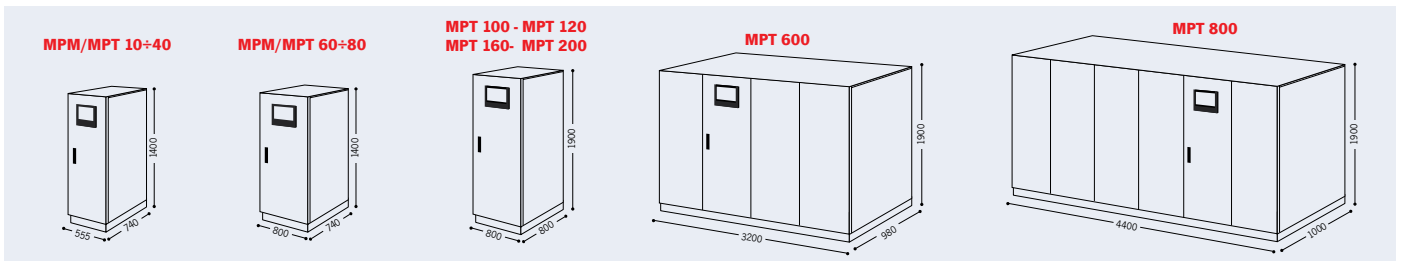

Battery box

MODELS	BB 1900 396-L6 / BB 1900 396-L7 BB 1900 396-L8 / BB 1900 396-L9	BB 1900 480-L6 / BB 1900 480-L7 BB 1900 480-L8 / BB 1900 480-L9	BB 1400 384-B1	BB 1400 384-B2 / BB 1400 384-B3 BB 1400 384-B4 / BB 1400 384-B5
MODELS UPS	MPT 100-200 MPM 100	MPT 600-800 MHT 100-500	MPT 10-60	MPT 10-80

Dimensions (mm)

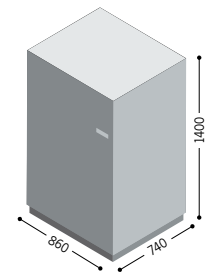
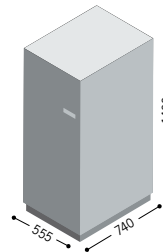
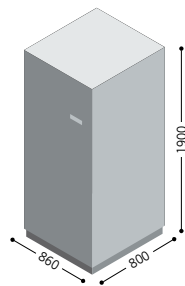

MODELS	TCE 270	TCE 400	TLE 400
MODELS UPS	MPT 100-200 / MPM 100	MHT 100-250	MPT D 600-800 / MHT 300-500

Dimensions (mm)

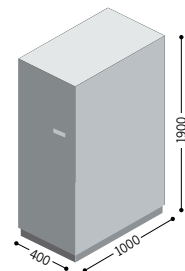
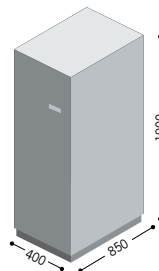
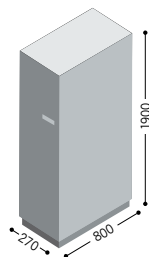

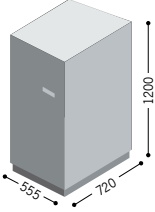
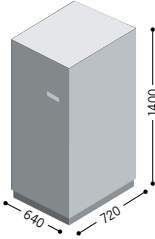
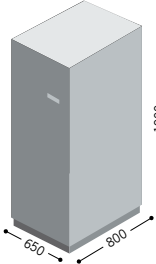
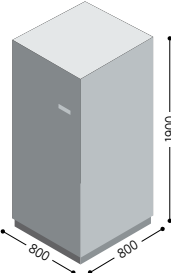
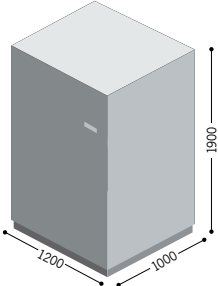
MODELS	TI 10 T / TI 15 T / TI 20 T TI 30 T / TI 40 T	TI 60 T / TI 80 T	TI 100 T / TI 120 T TI 160 T	TI 200 T / TI 250 T	TI 300 T / TI 400 T TI 500 T / TI 600 T
Dimensions (mm)					

OPTIONS

- Isolation transformer
- Synchronisation device (see UGS)
- Hot connection device (see PSJ)
- Generator interface
- Closed Loop parallel kit option
(Closed loop: to be ordered with the UPS)
- Battery cabinets

MODELS	MPM 10 *	MPM 15 *	MPM 20 *	MPM 30	MPM 40	MPM 60	MPM 80	MPM 100	
POWER	10	15	20	30	40	60	80	100	
INPUT									
Nominal voltage	380 - 400 - 415 Vac Three-phase								
Voltage tolerance	400 V + 20% /- 25%								
Frequency	45 - 65 Hz								
Soft start	0 ÷ 100% in 30" (selectable)								
Permissible frequency tolerance	± 2% (selectable from ± 1% to ± 5% from front panel)								
Standard equipment provided standard	Back Feed protection; separable bypass line								
BATTERIES									
Type	open lead acid and VRLA AGM / GEL; NiCd.								
Residual ripple voltage	< 1%								
Temperature compensation	-0.5 Vx°C								
Typical charge current	0.2 x C10								
OUTPUT									
Nominal power (kVA)	10	15	20	30	40	60	80	100	
Active power (kW)	9	13.5	18	27	36	54	72	90	
Number of phases	1								
Nominal voltage	220 - 230 - 240 Vac Single-phase								
Static stability	± 1%								
Dynamic stability	± 5% in 10 ms								
Voltage distortion	< 1% with linear load / < 3% with non-linear load								
Crest factor (I _{peak} /I _{rms})	3:1								
Frequency stability on battery	0.05%								
Frequency	50 or 60 Hz (selectable)								
Overload	110% for 60'; 125% for 10'; 150% for 1'								
INFO FOR INSTALLATION									
Net weight	200	220	230	290	340	440	520	650	
Dimensions (hwd) (mm)	1400 x 555 x 740					1400 x 800 x 740		1900 x 800 x 800	
Remote signals	volt-free contacts								
Remote controls	ESD and bypass								
Communication	Double RS232 + remote contacts + 2 slots for communications interface								
Ambient temperature	0°C / +40°C								
Relative humidity	< 95% non-condensing								
Colour	Dark grey RAL 7016								
Noise level at 1 m (dBA)	54		62			62		63	
Protection level	IP20								
Smart Active Output	up to 98%								
Regulations	Regulatory Directives LV 2006/95/EC - 2004/108/EC; IEC Safety EN 62040-1; EMC IEC EN 62040-2; IEC Performance EN 62040-3								
Classification according to IEC 62040-3	(Voltage Frequency Independent) VFI - SS - 111								

* Also available with internal batteries

MODELS	MPT 10 *	MPT 15 *	MPT 20 *	MPT 30	MPT 40	MPT 60	MPT 80
POWER	10	15	20	30	40	60	80
INPUT							
Nominal voltage	380 - 400 - 415 Vac Three-phase						
Voltage tolerance	400 V + 20% /- 25%						
Frequency	45 ÷ 65 Hz						
Soft start	0 ÷ 100% in 30" (selectable)						
Permissible frequency tolerance	± 2% (selectable from ± 1% to ± 5% from front panel)						
Standard equipment provided standard	Back Feed protection; separable bypass line						
BATTERIES							
Type	open lead acid and VRLA AGM / GEL; NiCd.						
Residual ripple voltage	< 1%						
Temperature compensation	-0.5 Vx°C						
Typical charge current	0.2 x C10						
OUTPUT							
Nominal power (kVA)	10	15	20	30	40	60	80
Active power (kW)	9	13.5	18	27	36	54	72
Number of phases	3 + N						
Nominal voltage	380 - 400 - 415 Vac Three-phase + N						
Static stability	± 1%						
Dynamic stability	± 5% in 10 ms						
Voltage distortion	< 1% with linear load / < 3% with non-linear load						
Crest factor (Ipeak/Irms)	3:1						
Frequency stability on battery	0.05%						
Frequency	50 or 60 Hz (selectable)						
Overload	110% for 60'; 125% for 10'; 150% for 1'						
INFO FOR INSTALLATION							
Weight without internal batteries (kg)	212	220	230	280	330	450	600
Dimensions (hwd) (mm)	1400 x 555 x 740					1400 x 800 x 740	
Remote signals	volt-free contacts						
Remote controls	ESD and bypass						
Communication	Double RS232 + remote contacts + 2 slots for communications interface						
Ambient temperature	0°C / +40°C						
Relative humidity	< 95% non-condensing						
Colour	Dark grey RAL 7016						
Noise level at 1 m (dBA)	54		60			62	
Protection level	IP20						
Smart Active Output	up to 98%						
Regulations	Regulatory Directives LV 2006/95/EC - 2004/108/EC; IEC Safety EN 62040-1; EMC IEC EN 62040-2; IEC Performance EN 62040-3						
Classification according to IEC 62040-3	(Voltage Frequency Independent) VFI - SS - 111						

* Also available with internal batteries

MODELS	MPT 100	MPT 120	MPT 160	MPT 200
POWER	100	120	160	200
INPUT				
Nominal voltage	380 - 400 - 415 Vac Three-phase			
Voltage tolerance	400 V + 20% /- 25%			
Frequency	45 ÷ 65 Hz			
Soft start	0 ÷ 100% in 30" (selectable)			
Permissible frequency tolerance	± 2% (selectable from ± 1% to ± 5% from front panel)			
Standard equipment provided standard	Back Feed protection; separable bypass line			
BATTERIES				
Type	open lead acid and VRLA AGM / GEL; NiCd.			
Residual ripple voltage	< 1%			
Temperature compensation	-0.5 Vx°C			
Typical charge current	0.2 x C10			
OUTPUT				
Nominal power (kVA)	100	120	160	200
Active power (kW)	90	96	144	180
Number of phases	3 + N			
Nominal voltage	380 - 400 - 415 Vac Three-phase + N			
Static stability	± 1%			
Dynamic stability	± 5% in 10 ms			
Voltage distortion	< 1% with linear load / < 3% with non-linear load			
Crest factor (I _{peak} /I _{rms})	3:1			
Frequency stability on battery	0.05%			
Frequency	50 or 60 Hz (selectable)			
Overload	110% for 60'; 125% for 10'; 150% for 1'			
INFO FOR INSTALLATION				
Weight (kg)	640	650	770	810
Dimensions (hwd) (mm)	1900 x 800 x 800			
Remote signals	volt-free contacts			
Remote controls	ESD and bypass			
Communication	Double RS232 + remote contacts + 2 slots for communications interface			
Ambient temperature	0°C / +40°C			
Relative humidity	< 95% non-condensing			
Colour	Dark grey RAL 7016			
Noise level at 1 m (dBA)	63 ÷ 68			
Protection level	IP20			
Smart Active Output	up to 98%			
Regulations	Regulatory Directives LV 2006/95/EC - 2004/108/EC; IEC Safety EN 62040-1; EMC IEC EN 62040-2; IEC Performance EN 62040-3			
Classification according to IEC 62040-3	(Voltage Frequency Independent) VFI - SS - 111			

MODELS	MPT 600	MPT 800
POWER	600	800
INPUT		
Nominal voltage	380 - 400 - 415 Vac Three-phase	
Voltage tolerance	400 V \pm 20%	
Frequency	45 \div 65 Hz	
Power factor	> 0.93 in HC version	
Current distortion	< 3% in HC version	
Soft start	0 \div 100% in 30" (selectable)	
Permissible frequency tolerance	\pm 2% (selectable from \pm 1% to \pm 5% from front panel)	
Standard equipment provided standard	Back Feed protection; separable bypass line	
BATTERIES		
Type	open lead acid and VRLA AGM / GEL; NiCd.	
Residual ripple voltage	< 1%	
Temperature compensation	-0.5 V \times °C	
Typical charge current	0.2 x C10	
OUTPUT		
Nominal power (kVA)	600	800
Active power (kW)	480	640
Number of phases	3 + N	
Nominal voltage	380 - 400 - 415 Vac Three-phase + N	
Static stability	\pm 1%	
Dynamic stability	\pm 5% in 10 ms	
Voltage distortion	< 1% with linear load / < 3% with non-linear load	
Crest factor (Ipeak/Irms)	3:1	
Frequency stability on battery	0.05%	
Frequency	50 or 60 Hz (selectable)	
Overload	110% for 60'; 125% for 10'; 150% for 1'	
INFO FOR INSTALLATION		
Weight (kg)	4000	5300
Dimensions (hwd) (mm)	1900 x 3200 x 1000	1900 x 4400 x 1000
Remote signals	voltage-free contacts	
Remote controls	ESD and bypass	
Communication	Double RS232 + remote contacts + 2 slots for communications interface	
Ambient temperature	0°C / +40°C	
Relative humidity	< 95% non-condensing	
Colour	Dark grey RAL 7016	
Noise level at 1 m (dBA)	< 75	< 78
Protection level	IP20	
Smart Active Output	up to 98%	
Regulations	Regulatory Directives LV 2006/95/EC - 2004/108/EC; IEC Safety EN 62040-1; EMC IEC EN 62040-2; IEC Performance EN 62040-3	
Classification according to IEC 62040-3	(Voltage Frequency Independent) VFI - SS - 111	

